

Ringo

last update 25/11/2015

BEL1053

Ringo A : code 504 . __

Ringo C : code 591 . __

GX53/6W - 230V - CE - IP65 -  -  - 

GX53/6W - 230V - CE - IP65 -  -  - 

Lamp
Micro Lynx F
6W
bulb not incorporated

BEL LIGHTING

BEL LIGHTING sprl
Avenue Ernest Solvay 42
B-1480 Saintes (Tubize)
Belgium
Phone: +32(0)2 3552428
Fax: +32(0)2 3550396
e-mail: info@bel-lighting.com
www.bel-lighting.com

INSTALLATION INSTRUCTIONS - PART A

1. FIT THE WALL FIXATION ON THE WALL
2. MAKE THE ELECTRICAL CONNECTION
3. PLACE THE LUMINARY
4. SWITCH ON

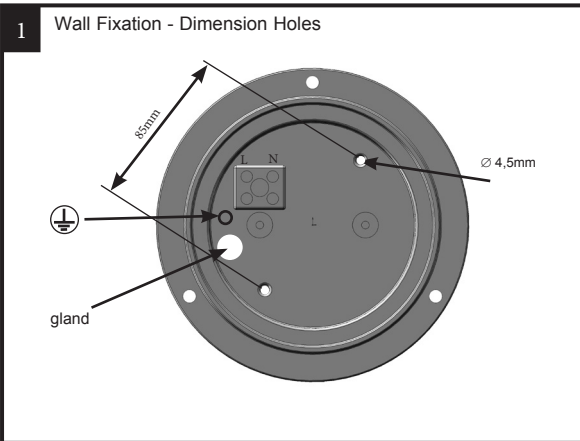

Ringo A

Ø142

Ø95

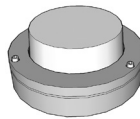

Ringo C

Ø142

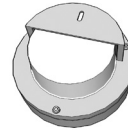

ACCESSORY SET

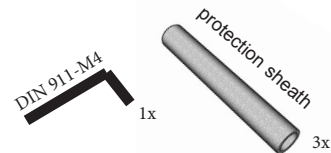

2 IMPORTANT : Gland for cable Ø8 ----> 11mm

- NL - Het einde van de wartels horizontaal insnijden (zeker niet in kruis)
FR - Couper le bouchon horizontalement à l'extrémité. (ne surtout pas couper en croix X)
EN - Cut horizontally the end of the gland (certainly not cut in cross)
DE - Das Oberteil der Kabelverschraubungen horizontal abschneiden (sicher nicht in Kreuz (X))
ΕΛ - Περικοπή οριζόντια το τέλος του αδένα (βεβαιώς που δεν κοβεται στο σταυρο X)

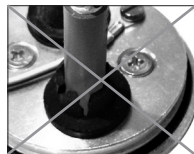
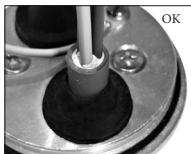
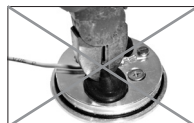

ELECTRICAL CONNECTION

- NL - Voeg de voedingskabel in de beschermingskoker
FR - Insérer le câble d'alimentation dans la gaine de protection.
EN - Insert the feeder in the protection sheath
DE - Das Kabel in die Schutzhülle einfügen
ΕΛ - Παρεμβάλετε τον τροφοδοτή στη θήκη προστασίας

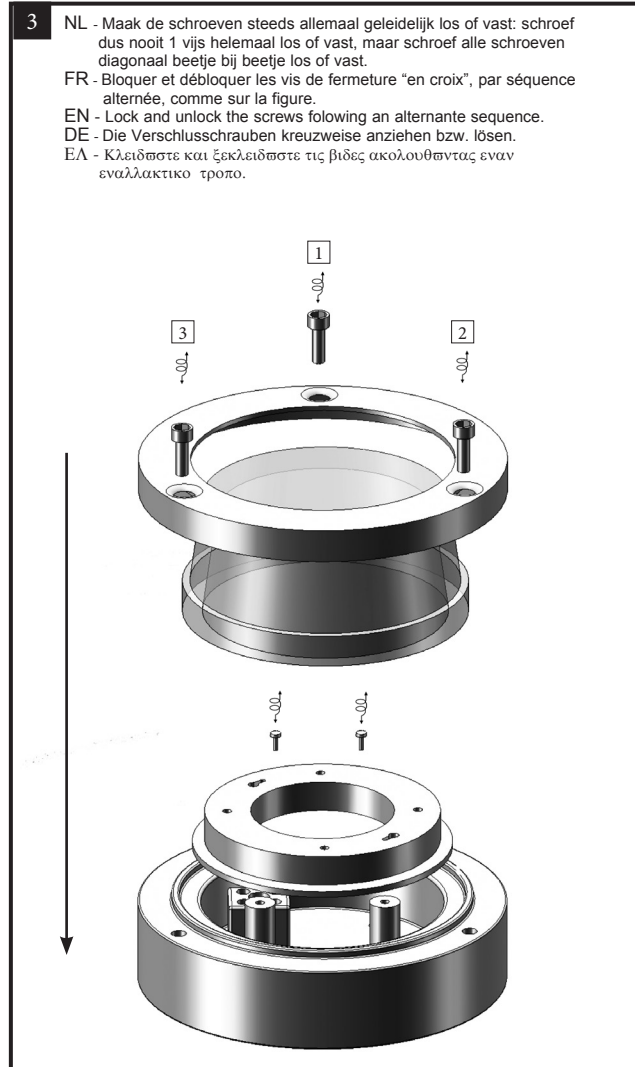
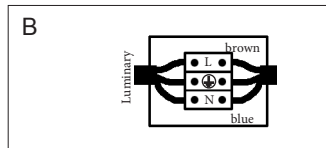
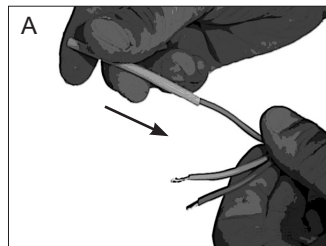

PART

A

Lees de algemene gebruiksvoorwaarden : PART B
Lire attentivement les conditions générales d'utilisation: PART B
Read attentively the general instructions: PART B
Lesen Sie die allgemeinen Gebrauchsanweisungen: PART B
Διαβάστε της γενικές οδηγίες : PART B

WAARSCHUWING
AVERTISSEMENT
WARNING
ΠΡΟΣΟΧΗ