

# Viva

last update 09/07/2015

BEL1094

**BEL LIGHTING**

BEL LIGHTING sprl  
Avenue Ernest Solvay 42  
B-1480 Saintes (Tubize)  
Belgium  
Phone: +32(0)2 3552428  
Fax: +32(0)2 3550396  
e-mail: info@bel-lighting.com  
www.bel-lighting.com

- Viva :** code 8021.W40.\_ \_ 18W (2x9W) - 230V~ - CE - IP20 - - -
- Viva :** code 8021.W20.\_ \_ 12W (2x6W) - 230V~ - CE - IP20 - - -
- Viva :** code 8021.EC.\_ \_ max.4x 50W QPAR16/GU-GZ10 - 230V~ - CE - IP20 - - -

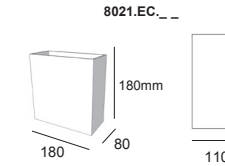
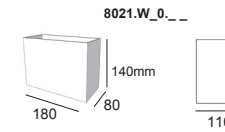

## INSTALLATION INSTRUCTIONS - PART A

1. FIT THE WALL FIXATION ON THE WALL
2. MAKE THE ELECTRICAL CONNECTION
3. PLACE THE LUMINARY
4. SWITCH ON

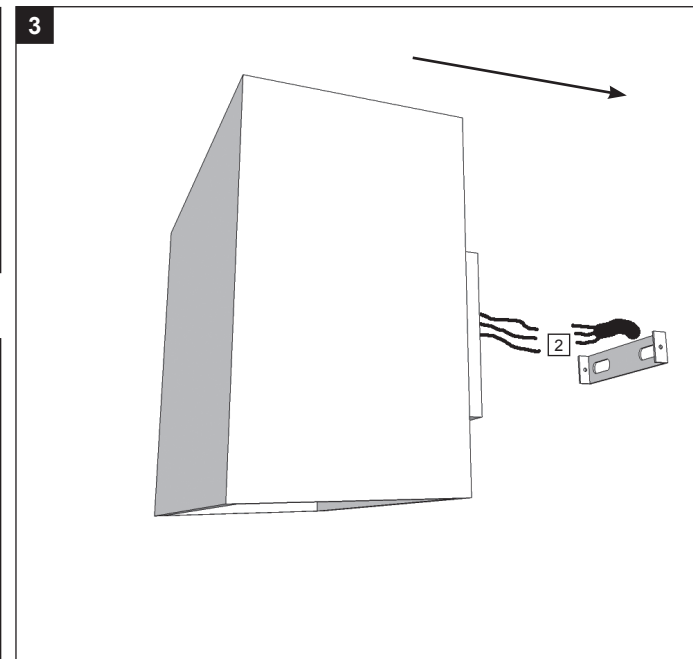
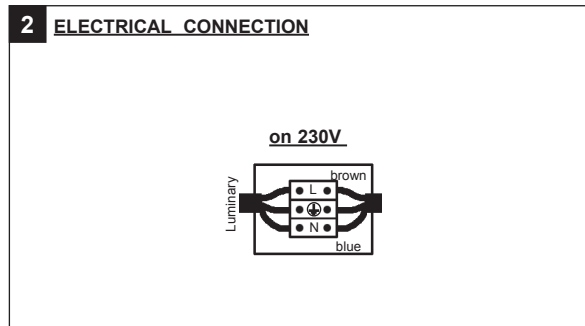
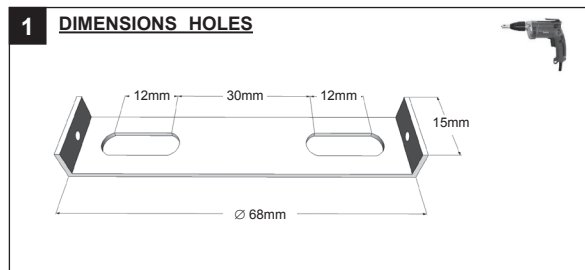

## PART A

Lees de algemene gebruiksvoorwaarden : PART B  
Lire attentivement les conditions générales d'utilisation : PART B  
Read attentively the general instructions : PART B  
Lesen Sie die allgemeinen Gebrauchsanweisungen : PART B  
Διαβάστε της γενικές οδηγίες : PART B

WAARSCHUWING  
AVERTISSEMENT  
WARNING  
WARNUNG  
ΠΡΟΣΟΧΗ