

Vodis

last update 05/02/2019

BEL1008

Vodis A : code 1139. __ max.25W G9 (LED max. diameter 17mm / height 56 mm) - 230V - CE - IP54 -  -  - 

Vodis B : code 1140. __ max.25W G9 (LED max. diameter 17mm / height 56 mm) - 230V - CE - IP54 -  -  - 



BEL LIGHTING sprl
Avenue Ernest Solvay 42
B-1480 Saintes (Tubize)
Belgium
Phone: +32(0)2 3552428
Fax: +32(0)2 3550396
e-mail: info@bel-lighting.com
www.bel-lighting.com

INSTALLATION INSTRUCTIONS - PART A

1. FIT THE WALL FIXATION ON THE WALL
2. MAKE THE ELECTRICAL CONNECTION
3. PLACE THE LUMINARY
4. SWITCH ON

1 WALL FIXATION - DIMENSION HOLES

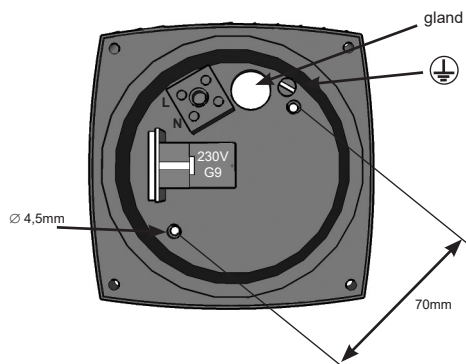

Vodis A

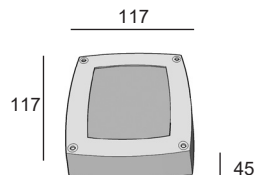

Vodis B

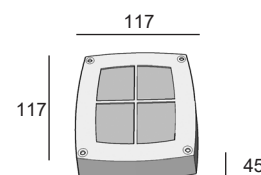

ACCESSORY SET

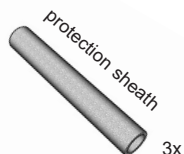

ELECTRICAL CONNECTION

- NL - Voeg de voedingskabel in de beschermingskoker
FR - Insérer le câble d'alimentation dans la gaine de protection.
EN - Insert the feeder in the protection sheath
DE - Das Kabel in die Schutzhülle einfügen
EL - Παρεμβάλετε τον τροφοδοτή στη θήκη προστασίας

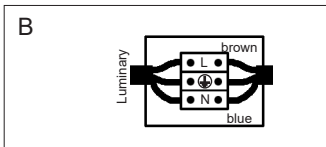
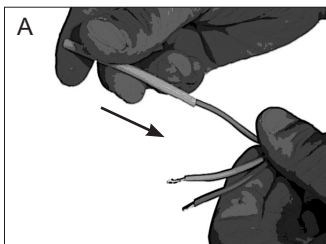

2 IMPORTANT : Gland for cable $\varnothing 3 \rightarrow 9\text{mm}$

- NL - Het einde van de wartels horizontaal insnijden (zeker niet in kruis)
FR - Couper le bouchon horizontalement à l'extrémité. (ne surtout pas couper en croix X)
EN - Cut horizontally the end of the gland (certainly not cut in cross)
DE - Das Oberteil der Kabelverschraubungen horizontal abschneiden (sicher nicht in Kreuz (X))
EL - Περικοπή οριζόντια το τέλος του αδένα (βεβαίως που δεν κοβεται στο σταυρο X)

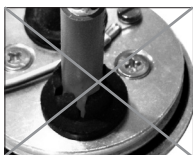
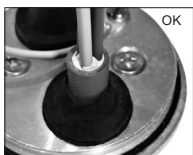
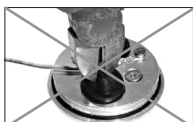

- 3 NL - Maak de schroeven steeds allemaal geleidelijk los of vast: schroef dus nooit 1 vijs helemaal los of vast, maar schroef alle schroeven diagonaal beetje bij beetje los of vast.
FR - Bloquer et débloquer les vis de fermeture "en croix", par séquence alternée, comme sur la figure.
EN - Lock and unlock the screws following an alternate sequence.
DE - Die Verschlusschrauben kreuzweise anziehen bzw. lösen.
EL - Κλειδώστε και ξεκλειδώστε τις βίδες ακολουθώντας έναν εναλλακτικό τρόπο.

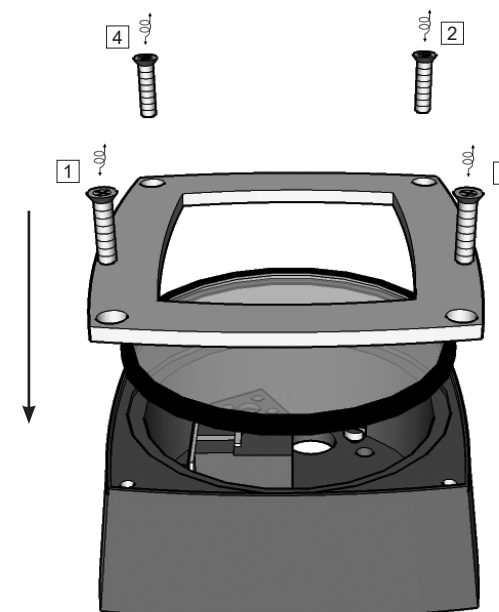

PART

A

Lees de algemene gebruiksvoorwaarden : PART B
Lire attentivement les conditions générales d'utilisation: PART B
Read attentively the general instructions: PART B
Lesen Sie die allgemeinen Gebrauchsanweisungen: PART B
Διαβάστε της γενικές οδηγίες : PART B

WAARSCHUWING
AVERTISSEMENT
WARNING
WARNUNG
ΠΡΟΣΟΧΗ